



Concrete Core Drill Motor Systems CM-10

OPERATOR MANUAL



KASKOD-MTRONIX OÜ

SAFETY CAUTION: BEFORE operating the equipment described in this Operator Manual, please carefully read the manual, to ensure safe operation. Always keep this Operator Manual with the described equipment.

CONTENTS

1.	Document Information	3
2.	Safety instructions	4
3.	Introduction	4
4.	Technical data	5
4.1.	Cuttronix® Concrete Core Drill Motor CM-10 (S1/S3/S6)	5
4.2.	Key features of CM-10S1, CM-10S3, CM-10S6 motor systems	5
4.3.	Key features of universal drill rig (UDR)	7
5.	CM-10 drill system description	8
5.1.	CM-10S1 Drill Motor Unit	8
5.2.	CM-10S3 Drill Motor Unit	9
5.3.	CM-10S6 Drill Motor Unit	9
6.	Preparation for core drilling	11
6.1.	Accessories needed for drilling	11
6.2.	Drilling rig assembly	11
6.3.	Mounting the carriage on the track	13
6.4.	Mounting extension track	14
6.5.	Fixing the base plate	14
6.6.	Drilling angle adjustment	14
6.7.	Spacer block mounting	15
6.8.	Carriage stopper	16
6.9.	Changing the spindle gearbox of the drill motor	16
6.10.	Mounting the motor on the carriage	16
6.11.	Hand crank mounting	17
6.12.	Water supply connection	17
6.13.	Mounting the drill bit on spindle	18
7.	The core drilling operation	18
7.1.	Power connection	18
7.2.	Drill motor control panel	19
7.3.	Drill motor operating modes	20
7.4.	Motor spindles RPM	22
7.5.	Start of core drilling	23
7.6.	Drilling through iron	23
7.7.	Angled drilling	23
7.8.	Drilling with a larger or a longer drill bit	24
7.9.	Core bit jamming	24
7.10.	Deep drilling with shaft extension	24
7.11.	Reverse gear	24
8.	Service time alert	24
9.	Maintenance	24
10.	Transportation	25
11.	Storage and preservation	25
12.	Troubleshooting	26
13.	Manufacturer's warranty	26
14.	End-of-life product disposal	27
15.	Declaration of conformity	28

1. Document information

Revision history:

Manual Version	5.1.2
Software Version	1.1
Revision Date	24.10.2019
Changes	three publication

Edition notice:

The contents of this document, including all graphics, are the property of KASKOD-MTRONIX OÜ. Information in this document is subject to change without notice. KASKOD-MTRONIX OÜ shall not be held under any legal obligations for technical or editorial errors or omissions contained herein. No part of this document may be changed, transmitted or reproduced in any form or by any means, electronic or mechanical, for any purpose, without the express written permission of KASKOD-MTRONIX OÜ.

Copyright ©:

2016-2019, KASKOD-MTRONIX OÜ. All rights reserved.

Trademark:

The following trademarks are acknowledged:

Cuttronix® and **ISRCdrive™** are trademarks of KASKOD-MTRONIX OÜ. All other trademarks are the property of their respective owners.

Contact address:

KASKOD-MTRONIX OÜ
Posti 27, Loksa, 74805 Harju maakond, Estonia
mail: info@kaskod.ee
www.cuttronix.com

2. Safety instructions



General precautions:

Before operation read carefully this User Manual

- The drilling system must be operated by trained and authorized personnel only.
- Do not operate the drill motor without personal protective equipment, such as hard hat, safety glasses, dust mask, gloves, and hearing protection.
- Do not operate a damaged machine. Check the motor before operating, it must be in a safe and trouble-free condition. Stop and check the machine if you hear strange noise from it; in case of a malfunction unplug and secure the machine.
- When machine is energized, observe all indicator lights and check if any warnings or alarms are present.
- Never operate without proper motor balance and without motor and drill rig having been properly secured.
- Make sure that anchor bolts reliably fix the base plate to uneven or vertical surfaces.
- Do not operate the machine if you are tired, feel unwell or are under the influence of alcohol, drugs, or any incapacitating medication.
- Keep head and body parts away from machine's openings and moving parts. Wear tight-fitting clothing and accessories.
- Do not use the wet coring without water. Water flow rate and pressure must be supplied according to the data provided in this user manual.
- Use diamond core drill bits ONLY with this drill motor.
- Do not apply too much force to the drill machine. Make sure the drill motor is used properly and as intended.
- Remove all adjusting keys or wrenches before energizing the power tool, failure to do so may result in personal injury.
- Be careful when drilling through walls or through ceilings, as drilled material or the core may drop out and fall down.
- Do not operate the machine when flammable materials or vapors are present. Electrical equipment can create sparks or arcs which can result in a fire or an explosion.
- Be careful during the machine operation, a damaged core drill bit or a loose heavy piece of concrete core can cause very strong vibration which may lead to the weakening of drill fixture or stand anchoring. Operator must stop the machine and fix the problem.
- Keep the machine away from children.



Electrical safety:

- Use the drill only with protective devices (i.e.

circuit breakers, noise absorbers, leakage current circuit breakers (RCD or GFCI).

- To minimize electric shock, do not operate the machine in rainy or wet conditions.
- Do not operate the machine if the power cable is damaged. Power voltage must be as specified on the drill motor nameplate.
- Do not operate the machine unless the power plug is connected to the properly grounded receptacle; grounded receptacles reduce risk of electric shock.
- Unplug the machine when you are not using it, prior to servicing, or when changing accessories.
- Never lift or carry the machine by the power cord. Do not pull by the cord to unplug. Keep cord away from heat, sharp edges and oil.
- Before energizing the machine, make sure that the power connector is dry.
- Use only appropriate extension cords and adapters, especially when working outdoors.
- Never leave the energized machine unattended.



The work area:

- Keep work area well-lit and clean.
- Before drilling, check the work area to ensure that no energized electric cables or gas and water pipes under pressure are present in the objects you intend to drill. If present, electric cables must be de-energized securely, so they are not allowed to re-energize; water and gas pipes must be securely disconnected from the pressurized network. Water from pipes must be drained, residual gas from gas lines must be let out.
- Don't work from a ladder.



Service:

- Service on the drill must be performed only by a KASKOD-MTRONIX certified service center technician. The spare parts must be original. This will ensure that the safety and integrity of the power tool is maintained.
- Incorrect handling or inappropriate maintenance of the tool may cause damage before actually using the tool. KASKOD-MTRONIX is not responsible for property damage or personal injury in such cases.

3. Introduction

KASKOD-MTRONIX OÜ mechatronic manufacturing and development company provides technically innovative solutions based on ISRCdrive™ technology.

Our company is proud to introduce a new product whose technological advantages will raise the bar for the concrete cutting tools to a new level through significant innovation in several areas and will

introduce new technologies to the concrete cutting industry. Meet the integrated concrete core drilling systems Cuttronix® CM-10S1, CM-10S3, CM-10S6 (based on CM-10 drive).

The product contains the following innovative elements:

- The innovative concrete core drilling system with unbeatable power/weight ratio, based on a specially developed fully integrated ISRCdrive™ motor technology – with high output power and very rugged design, equipped with a digital motor control system.
- The drill motor with high efficiency, high output power, wide RPM range, low weight and small dimensions. It can be used for drilling of any types of surfaces and all sorts of concrete.

4. Technical data

4.1 Cuttronix® Concrete Core Drill Motor CM-10 (S1/S3/S6)

CM-10 (S1/S3/S6) high power, high cycle core drilling motor - offers high performance, efficiency, productivity and reliability. The motor are based on KASKOD-MTRONIX ISRCdrive™ Technology and combine in one product at least two core drill motors with single-phase and three-phase input power.

There is no external inverter box needed! To connect to single-phase or 3-phase power source, only an adapter cable is required.

The motor can be supplied with three different changeable spindle gearboxes SG15, SG30 or SG60.



4.2 Key features of CM-10S1, CM-10S3, CM-10S6, motor systems:



System Type	CM-10S1		CM-10S3		CM-10S6	
Spindle Gearbox Type	SG15		SG30		SG60	
Power type	1-phase 230 Volt	3-phase 400 Volt	1-phase 230 Volt	3-phase 400 Volt	1-phase 230 Volt	3-phase 400 Volt
Input power (kW)	3.6	11	3.6	11	3.6	11
Rated output power (kW)	3.0	10	3.0	10	3.0	10
Input voltage (V)	230 - 250	400 - 480	230 - 250	400 - 480	230 - 250	400 - 480
Input frequency (Hz)	50 - 60					
Spindle (rpm)	80 - 1600	80 - 2000	40 - 800	40 - 1000	20 - 400	20 - 500
Core bit diameter (mm)	20-400		40-400 with motor on carriage 400-800 with one spacer block		40-600 with motor on carriage 600-1000 with one spacer block	
Spindle torque (Nm)	150		300		600	
Weight (kg)	20		21.5		27	
Dimensions (mm)	576 x 176 x 241		576 x 176 x 248		612 x 176 x 388	
Antilock core bit coupling.	+		+		+	
Protection class	IP66					
Operating temperature range C°	+5 ÷ +50 C°					
Storage temperature range C°	-40 ÷ +85 C°					

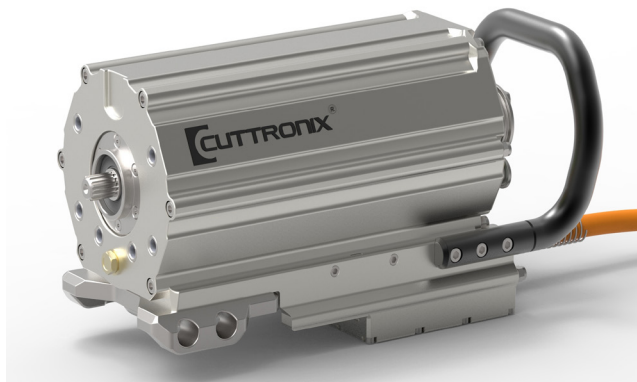

CM-10 Drive unit



SG15 gearbox



SG30 gearbox

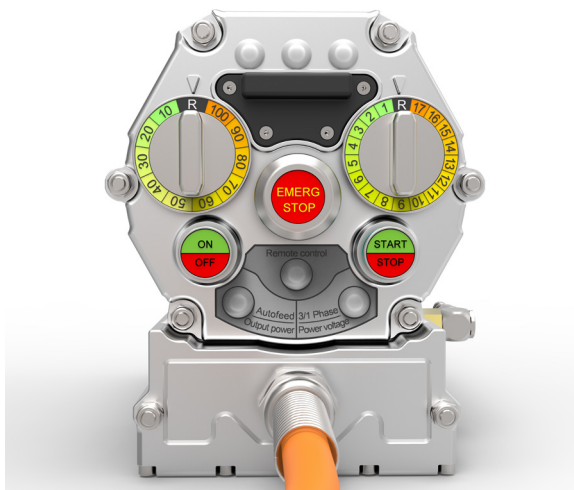

CM-10 control panel



SG60 gearbox

- **Motors** - Long life and reliability are achieved by utilizing a rigid design and the best possible quality of materials. The motors are completely encapsulated with thermally conductive motor compound for good cooling, mechanical strength and moisture resistance.
- **High efficiency** - over a wide speed range.
- **Very low maintenance** - due to use of brushless motors without windings or magnets in the rotor and extremely rugged and simple construction.
- **Motor Protection** - digital motor control system provides protection against overload, overheating, and overvoltage.
- **Durable planetary gear with changeable spindle gearboxes (SG15, SG30 or SG60)** - ease of maintenance.
- **Reliable slip clutch** - gearbox damage protection
- **Wide input voltage range** - the drill motor accepts a wide voltage range:
 - Option1: - Europe:** single phase 230V, three phase 400V.
 - Option2: - USA:** split phase 240V, three phase 200-240V, 480V.
 - Option3: - USA, Japan:** single phase 110V, split phase 240V, three phase 200-240V.
- **Power Line monitor:** - indicates type of input voltage, voltage level and a missing phase.
- **Output Power Limit Wheel:** - wide range control of output power to prevent damage of core drill bits of smaller diameter.
- **Electronic system resistant to voltage surges** - impervious to frequency and voltage fluctuations.
- **Mechanical gear + 17 electronic gears and Reverse** - due to torque motor with a single-speed reduction gearbox, accepts drill bit diameter of up to 800 mm (with SG30 gearbox) and 1000 mm (with SG60 gearbox).
- **Antilock coupling for drill bit** - motor can be supplied with different spindle threads or with an antilock coupling.
- **Bright color LEDs** - for motor load and input voltage levels indication.
- **Very durable buttons and switches** - made of metal, without mechanical dirt- or dust-sensitive contacts and switches.
- **Built-in compact EMC-filter** - ensures very low electro-magnetic emission levels.
- **Service alert** - Integrated real time clock and hour counter which informs the operator about service time.
- **Protection class IP66** - protected against strong jets of water.
- **Durable metal case** - made of extruded aluminum
- **Very rigid drill stand with extreme stability** - can handle small and large drill bits.

4.3 Key features of universal drill rig (UDR):

- Lightweight adjustable-angle stand for manual and automatic drilling and wire sawing

applications.

- Extreme stability: robust and rigid, for reliable professional use.
- Made with the highest quality materials with the most advanced manufacturing technology.
- Quick release motor mount, for easy installation.
- Removable wheels for easy mobility and transportation
- Stackable column length, 1100 mm and 1980 mm sections.
- Base plate: 220x330 mm.
- Stable threaded clumped connection between column and base plate.
- 4 Leveling screws on base plate.
- 3-spoke stainless steel hand crank (can be used on right or left side).
- Column weight: 7,2 kg/m.
- CR-M Motor carriage, manual feed, reduction 4,63:1 - 6,2 kg.
- 4 adjustable guide carriages with 8 rollers for precise and low-vibration drilling.



SB-150 Spacer Block

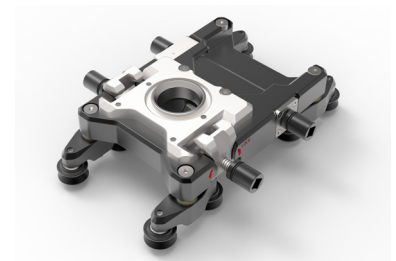

CR-M Carriage



UDR110-2 assembled of two 1100 mm columns



UDR198 1980 mm column



UDR110
1100 mm column



UDR110-CR-M
manual feed rig assembly

5. CM-10 drill motor system description

The drilling system consists of following units:

- The drill motor unit which is an integrated brushless motor, with output power of 3,0 kW when motor is connected to single-phase power (230V) or 10 kW when connected to 3-phase power (400V). Into the housing of the drill motor three main parts are integrated: a heavy duty switched reluctance motor, an electronic unit and a reliable gearbox which provides high output torque.
- Universal Drill Rig with carriage.

5.1 CM-10S1 Drill Motor Unit

The CM-10S1 drill motor system includes CM-10 drive unit and SG15 spindle gearbox.



5.2 CM-10S3 Drill Motor Unit

The CM-10S3 drill motor system includes CM-10 drive unit and SG30 spindle gearbox.



5.3 CM-10S6 Drill Motor Unit

The CM-10S6 drill motor system includes CM-10 drive unit and SG60 spindle gearbox.



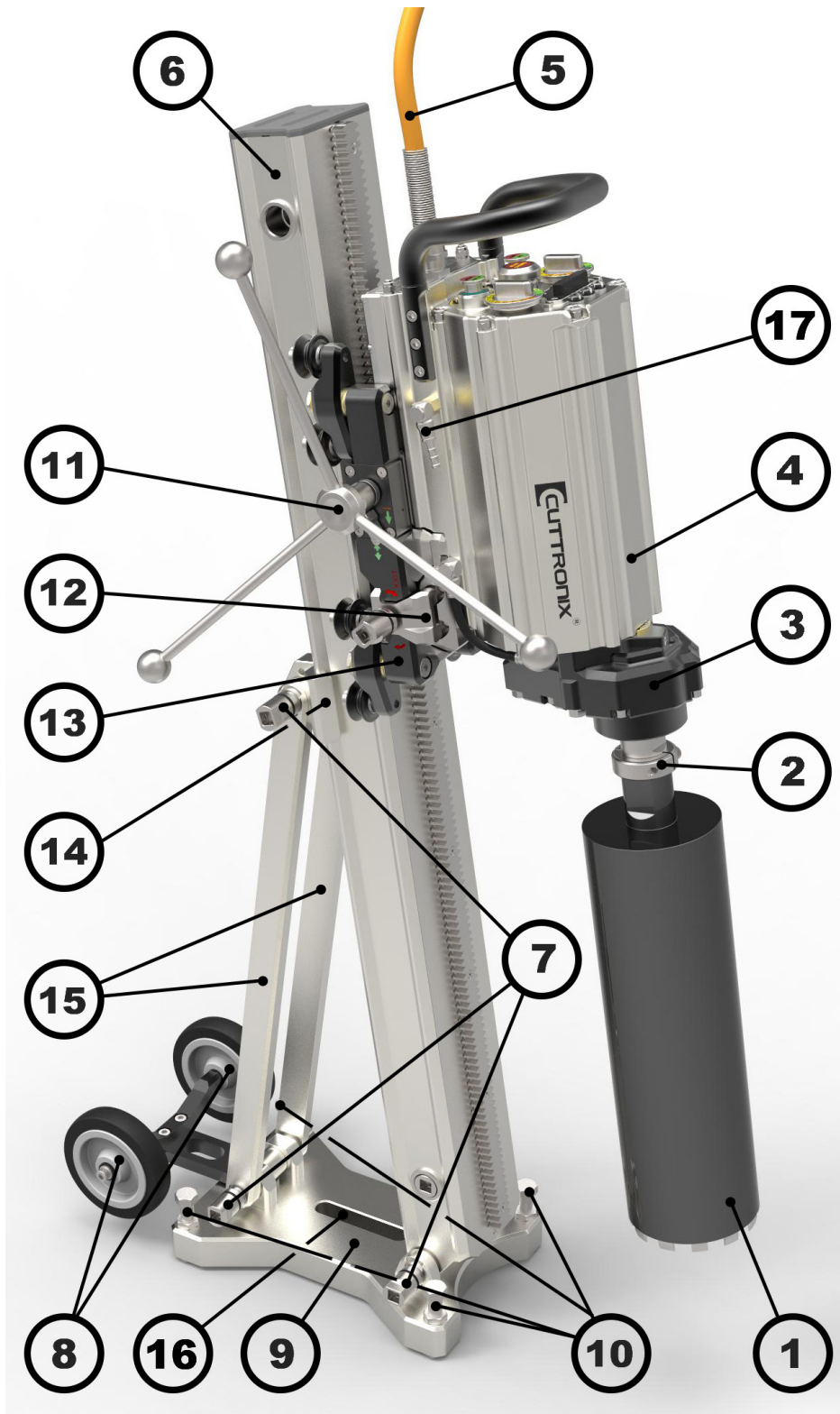

- 1- The Diamond Core drill bit
- 2- Spindle antilock collar
- 3- Spindle gearbox
- 4- CM-10 motor drive unit
- 5- Power cord of motor drive unit
- 6- Drill rig track
- 7- Drill rig angle adjustment screws
- 8- Drill rig wheels
- 9- Base plate

- 10- Four leveling screws
- 11- Crank feed shaft
- 12- Motor clamp
- 13- CR-M motor carriage with rollers
- 14- Back support braces
- 15- Track support rails
- 16- Base plate anchor slot
- 17- Water hose connector

6. Preparation for core drilling

6.1 Accessories needed for drilling

The operator working with core drilling systems should have the following accessories (including but not limited to):

- Individual protective equipment: Helmet and ear protectors, goggles, safety gloves; close-fitting sturdy, comfortable clothing, respirator mask, work boots with anti-slip soles and steel toe caps;
- Adapters and shaft extension rods for diamond core drill bit mounting;
- Cables and extension cords with sockets to plug the drill motor into power network;
- Parts for water connection: water hose, valve, fittings;

- Hammer drill, to drill the holes for securing the anchors;
- Securing anchors, for base plate fixing;
- Hammer for securing the anchors;
- Anchor bolts for base plate mounting;
- Drilling core extraction device and auxiliary and lifting equipment;
- 1/2-Inch Wrench Ratchet Square Drive, 6mm hex (Allen) wrench and 21 mm wrenches for drill stand mounting and adjustments;
- Level measuring device to set up the drill rig in accordance with the necessary position requirements;
- Tape measure for base plate positioning;
- Water collection ring - to collect and carry away cooling and flushing water;
- Water and dust vacuum cleaner for slurry collection.

6.2 Drilling rig assembly

1. Track
2. Base plate
3. Downside screw of support rails
4. Rig wheels
5. Back support braces
6. Track support rails
7. Track fixing screw
8. Track fixing screw nut
9. Downside and Upside washers of support rails
10. Downside and Upside nuts of support rails
11. Track wheels screw
12. Pin guide for support braces
13. Back support braces screw
14. Track support screw

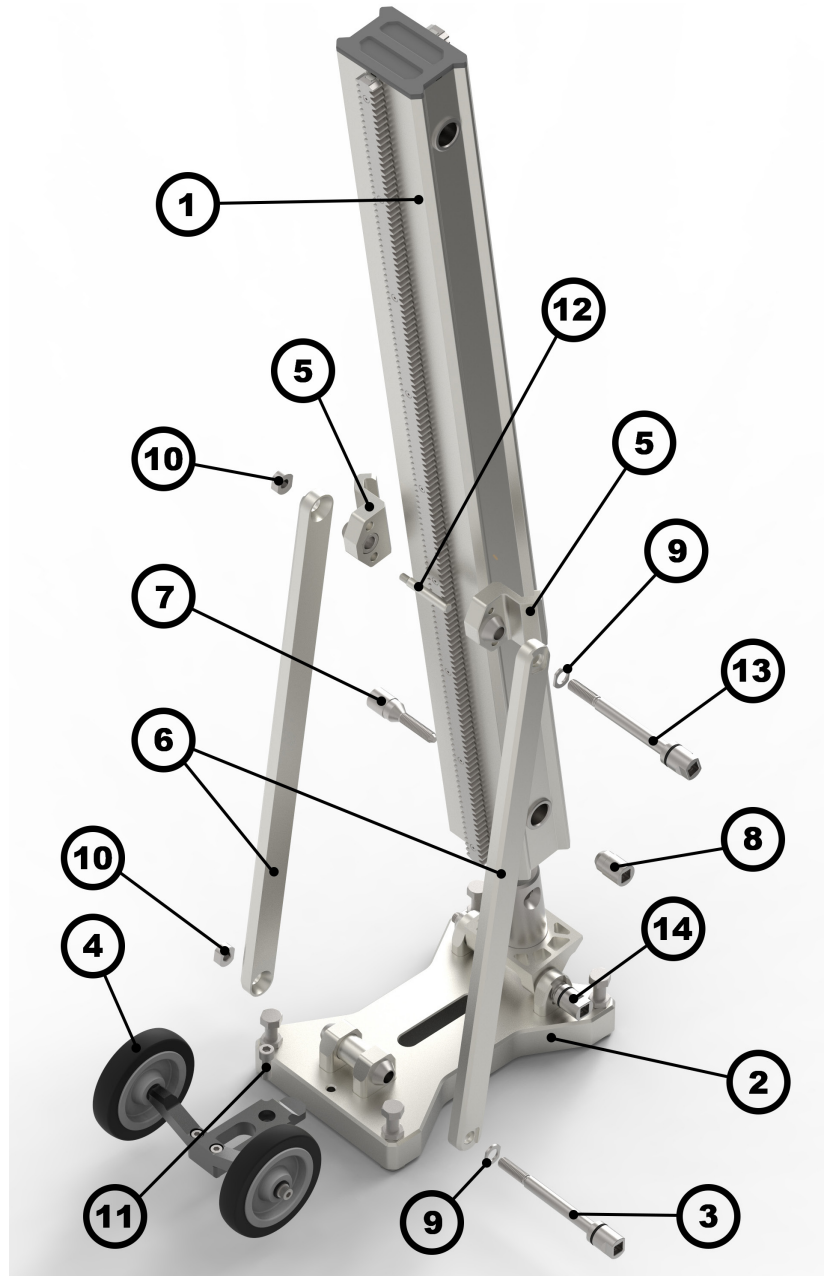

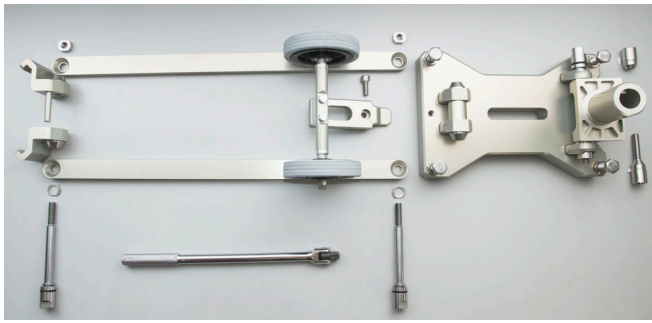

Drill rig mounting sequence:

- The track support rails (6) are mounted onto the base plate (2).
- The back support braces (5) are mounted onto the track support rails (6).

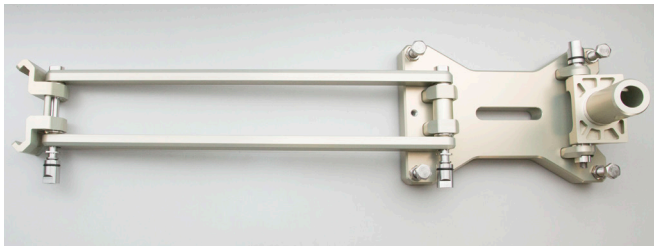

- The track (1) is mounted onto the base plate (2), maximum tightening torque 50 Nm.



- The rig wheels (4) are mounted onto the base plate (2), maximum tightening torque 20 Nm.



- The back support braces (5) are fixed to the track (1), maximum tightening torque 50 Nm.

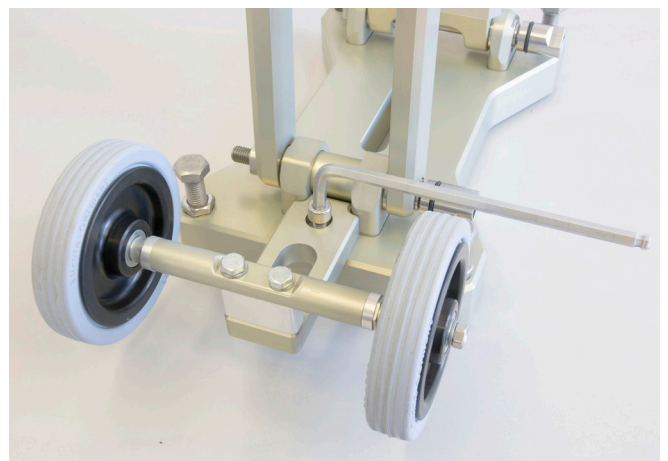

6.3 Mounting the carriage on the track

There is a direction latch lever on the carriage which prevents carriage from sliding along the track. There are three positions: to move Down, Neutral (for drilling, carriage can be moved up or down, marked with a bi-directional arrow), and to move Up.



Put the direction latch lever to Neutral position. Put the carriage on the rig and slide it down. Put the direction latch lever to "Move UP" position, in this position the carriage will not slide down on the rig.



Make sure the rollers of guide carriages are adjusted for tight fit to the rig and the carriage does not wobble. To adjust the rollers of guide carriage, use a 6 mm hex (Allen) key and a 23 mm wrench.

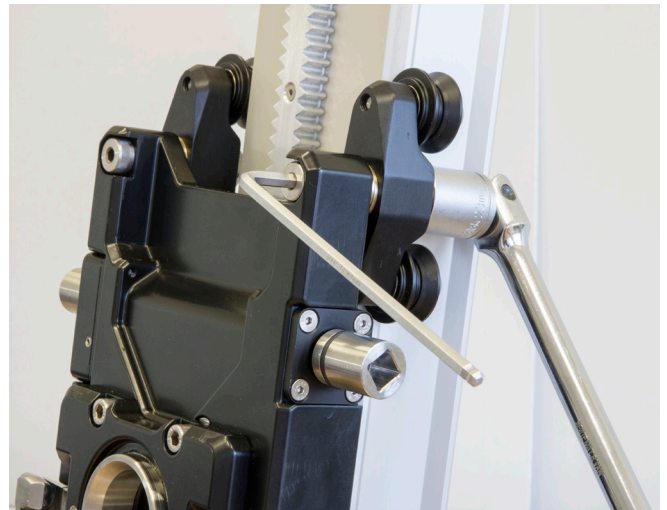

Loosen the fixing screw, using a hex (Allen) key, and turn 23 mm wrench on the other side, pressing the rollers of guide carriage to the track.

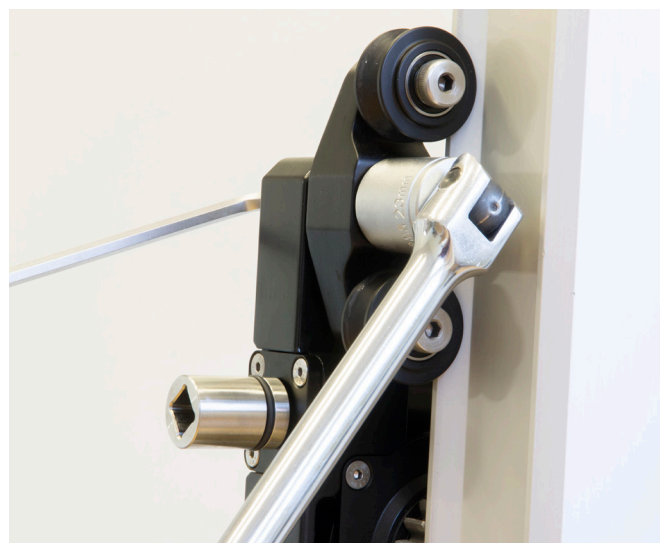

Tighten the fixing screw of the guide carriage, with maximum torque 20 Nm. The rollers should be hugging the track pretty tight to prevent carriage from wobbling. Repeat the same procedure for the lower guide carriage rollers.

 **WARNING:** Do not over-tighten the screws, as the thread can be damaged!

When drilling vertically down (floor) or horizontally (wall) the lever should be in the "middle" position so that drill can be easily moved up or down (forward and backward).

When drilling vertically up (ceiling), position of the lever should be the "down" position to prevent drill motor from falling on the operator.

 **Note:** The direction switch can get "stuck" when drill is mounted, and in this case, to get it to move freely again, it is necessary to move the drill slightly with the crank, just one click is enough, and then move the switch again, it should move freely to another position at that point.

6.4 Mounting extension track:

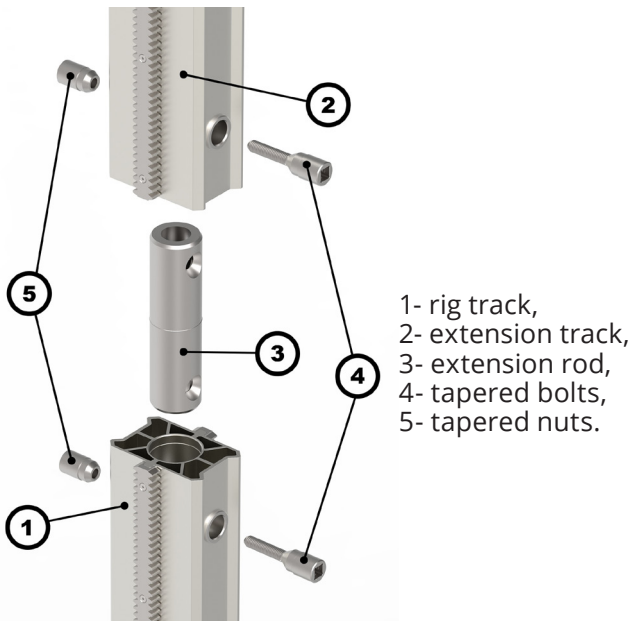

The drill rig with 1100 mm track allows using only core bits with a maximum total length of 750 mm. To mount the extension track, insert the extension rod into the hole at the end of the rig track. Fix and slightly tighten the extension rod with tapered bolt and nut on the rig track. Put the extension track on the top of the rig track. Fix the upper track with tapered bolt and nut and tighten the bolts on both tracks, with torque not to exceed 50 Nm

Make sure there is no gap between the tracks and they are fixed tightly.

 **WARNING:** Be careful during the track installation, the upper part of the track may fall and cause injury!

6.5 Fixing the base plate

Using a hammer drill, drill a hole in the concrete for fixing the base plate. Expand the anchor into the concrete so it is locked in tight. Screw the threaded rod into the anchor through the middle of the slot in the base plate of the drilling rig and the clamping nut onto the threaded rod. Fix the base plate to concrete with metal expansion anchor and a bolt of minimum M14 diameter. Level the base plate by turning the four leveling screws. Make sure the base plate is properly secured!

 **WARNING:** An unsecured rig could rotate during drilling and possibly cause injury. When working on brick or light concrete, the base plate can be fixed with bolts passing through the wall or concrete slab.

For drilling holes larger than 0.4 meter in diameter, or holes deeper than 1.5 meter use two anchors, not less than M16 size, as widely spaced in the drill base anchor slot as possible.

 **NOTE:** Do not use hammer or other heavy objects for base plate adjustment, this can damage the base plate.

6.6 Drilling angle adjustment

Loosen the track support screw near the base plate. Loosen the screw on the track support rails. While firmly holding the track, loosen the upper screw on the back support braces and tilt the track backward or forward to the desired angle. Tighten all the screws: on the track support, on the lower back support, and on the upper back support braces (max torque 50 Nm).



6.7 Spacer block mounting

To use core bits with diameter greater than 400 mm, the distance between the drill track and the drilling axis needs to be increased by mounting a spacer block.

For spacer block mounting, open the motor clamp of the carriage.

Place the spacer block on the carriage and tighten the clamp (max torque must not exceed 40 Nm).

To mount the motor on the spacer block, open the motor clamp of the spacer block.

Place the motor on the spacer block and tighten the clamp.



WARNING: If the track is tilted forward, make sure that there is no risk of damaging base plate.



WARNING: Do not over-tighten the screws (max torque 50 Nm), as the thread can be damaged!



NOTE: Before mounting the drill motor, make sure that carriage lever is in such a position that doesn't allow the carriage with spacer block and drill motor slide along the track.



WARNING: Before mounting the drill motor on the carriage make sure that the drill motor is disconnected from electric power.

6.8 Carriage stopper

Carriage stopper can be used to limit drilling depth.

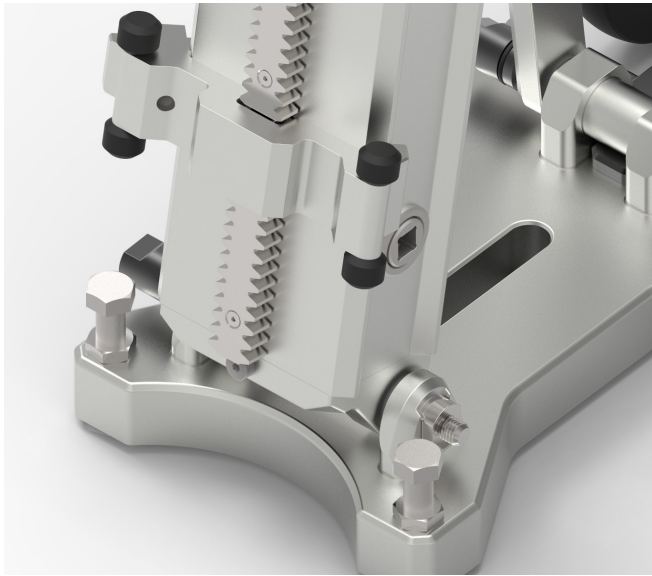

6.9 Changing spindle gearbox of the drill motor

Depending on the drill bit size, three types of spindle gearboxes (SG15, SG30 or SG60) can be used. To detach the gearbox unit from the motor, use a 17 mm socket. Loosen and remove the four screws on the spindle gearbox unit. Pull the spindle gearbox unit off the CM-10 drive unit. To mount the gearbox on the drive unit, align the holes in the gearbox with the holes on the unit, insert the splined drive shaft into the motor drive unit and gently push the gearbox unit onto the splined drive shaft of the drive unit. Make sure that the gearbox unit is fixed on the drive unit properly and there is no gap between gearbox and drive unit. Tighten four screws with a 17 mm socket wrench with torque not to exceed 44 Nm.

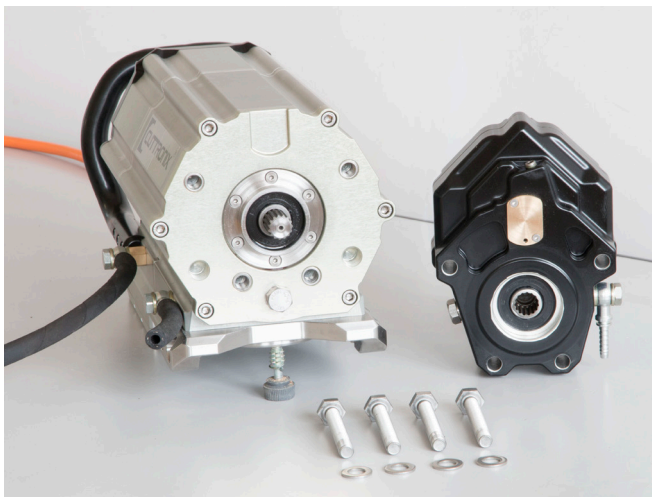

NOTE: Do not tighten the spindle gearbox screws if the gap between gearbox and drive unit is present.

WARNING: Do not over-tighten the screws (max torque - not to exceed 44 Nm), as the thread can be damaged!

6.10 Mounting the motor onto the carriage

Open the motor clamp of the carriage. Place the motor on the carriage and tighten the clamp (max torque - not to exceed 40 Nm).



side, shafts provide drive of the carriage through reduction gearing. Instead of the manual feed crank a 1/2-Inch Wrench Ratchet Square Drive can be used.

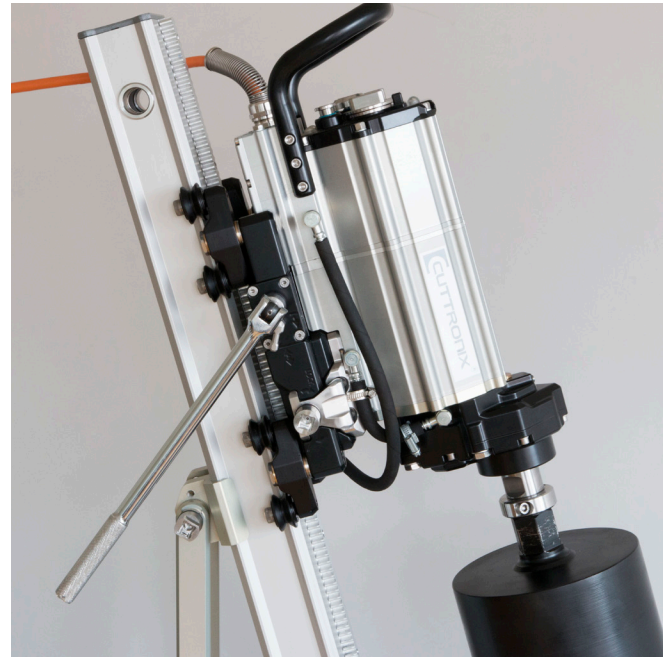

WARNING: Before mounting the drill motor on the carriage make sure that the drill motor is disconnected from electric power.



NOTE: Prior to drill motor mounting make sure that carriage lever is in such a position that doesn't allow the carriage with the drill motor slide down along the track.

6.11 Hand crank mounting

The hand crank can be mounted on the left-hand side or the right-hand side of the carriage. On either

6.12 Water supply connection

A proper water supply is required during the wet drilling, since the water cools the drill motor and the core bit, and flushes the slurry created during the cutting process off the cutting area. Connect the water supply hose with a valve to the hose connector on the core drilling machine.



WARNING: Use clean water only, as dirty water may cause machine damage!



WARNING: If the drill motor gets overheated, increase the water flow to prevent the motor failure. The water temperature must not exceed +40 C° (104°F)



WARNING: minimum permissible water supply rate must not be less than 4 liters per minute and pressure must not exceed 7 bar.



WARNING: Don't leave the motor with water inside at ambient temperatures less than + 5 C° (41°F). Drain the water from the motor (see chapter 9)

6.13 Mounting the drill bit on spindle

The size and peripheral speed of diamond core drill bit should be selected according to the drilled material quality and the hole diameter. The motor spindle gearboxes (SG15, SG30, SG60) are equipped with a standard 1-1/4-7" UNC thread. The cores with other type of thread require use of adapters. The motor spindles are equipped with antilock collar for easier removal of the core bits. Before mounting the core bit, tighten the screw of antilock coupling and grease the spindle, to facilitate removal of the core bit. The core bit has a right-hand thread, use an open-end wrench SW 32 to hold the spindle in place. For removing the core bit, use open-end wrenches SW 41 and SW 32. To thread off the core bit, loosen the screw of the antilock collar, then the core bit will be much easier to remove.



The reverse gear can be used for removing the diamond core drill bits. When RPM wheel is set to "R" the spindle rotation will first automatically stop. Push the motor **START/STOP** button and the spindle starts slowly rotating in reverse direction.



NOTE: Never hit the motor spindle or the core bit in order to remove the bit as the gearbox of the drill motor can be damaged!



WARNING: Be careful, the core bit may fall and cause injury!



WARNING: Remove all the wrenches from the motor spindle or core bit before energizing the motor, failing to do so may result in personal injury.



WARNING: Before starting the drill motor, make sure that the core bit is fixed properly on the drill motor spindle.



7. The core drilling operation



WARNING: Read safety instructions in Chapter 2 of this Manual before operation!

7.1 Power connection

The Cuttronix CM-10 core drill must be connected to grounded 1-phase or 3-phase power outlets only!



WARNING: Make sure that the metallic parts of the core drill motor and the whole system (extension cords, sockets etc.) are connected to the ground. If you are not sure, ask a qualified electrician for a check.



WARNING: Always power from a circuit protected by a circuit breaker with correct current rating (16A). DO NOT connect the motor to power line without a circuit breaker and Ground Fault Circuit Interrupter (GFCI or RCD)!



NOTE: In case of overly sensitive fuses (breakers) it is possible to decrease power consumption of the motor by using power limit wheel. By turning from position 100 down to 90, 80, .. to 10 the output power and power consumption of the motor can be decreased to levels between 90% and 10%.



WARNING: Prior to plugging the drill motor into a power supply, inspect power cord, extension cord and power connectors, and replace them if they are damaged. Before connection make sure that the local mains voltage corresponds to the operating voltage shown on the motor baseplate!

Always use extension cords or equipment that is rated for the level of amperage and wattage of the motor that you are using.



WARNING: Before drilling, do not block access to electric panels and circuit breakers or other electrical protective equipment. For single-phase 230-240V power connection, use the adapter cable.



7.1.1 Powering the drill motor from a generator or a transformer

When a transformer or a generator is required, it is important to select one that is correctly sized for your equipment or else you could run into problems.

Single-phase 230V AC voltage 50/ 60 Hz, power output must be at least 8.000 VA (8 kVA). The operating voltage must at all times be within ±10% of the rated voltage (230V).

Three-phase 400V AC voltage 50/ 60 Hz, power output must be at least 20.000 VA (20 kVA). The operating voltage must at all times be within ±10% of the rated voltage (400V).



NOTE: If generator or transformer are overloaded, during switching on and off the power of the drill motor overvoltage power peaks may occur, resulting in damage to the core drilling machine. Never operate more than one machine from one generator or transformer at the same time.

7.2 Drill Motor control panel

1 - Load indicator and motor status LEDs - when the motor is operating, they indicate the motor load percentage; during the test they indicate the motor status.

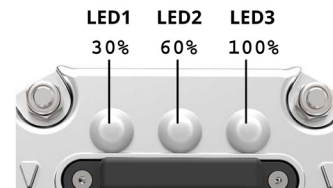

2 - Remote control LED, indicates status of service computer connection.

3 - Cap of service computer connector.

4 - Output Power Limit wheel - sets the motor output power level.

5 - Spindle Speed Wheel - sets drill motor spindle speed.

6 - EMERGENCY STOP Button - button for a quick stop of the motor to prevent injury or damage.

7 - START/STOP BUTTON - starts and stops the drill motor and unblocks the drill motor after the Emergency Stop Button has been activated.

8 - Output Power Limit ON/OFF Button - turns on the output power limiting functionality. Output power LED 10 will be lighted in this mode, output power level can be chosen in the range between 10% and 100% by rotating wheel 4.

9 - Input Power line status LED - indicates power line voltage and connection.

10 - Output Power Limit LED - indicates the motor operation with limited output power, when Output Power Limit Button is turned on.

11 - Power cable connection

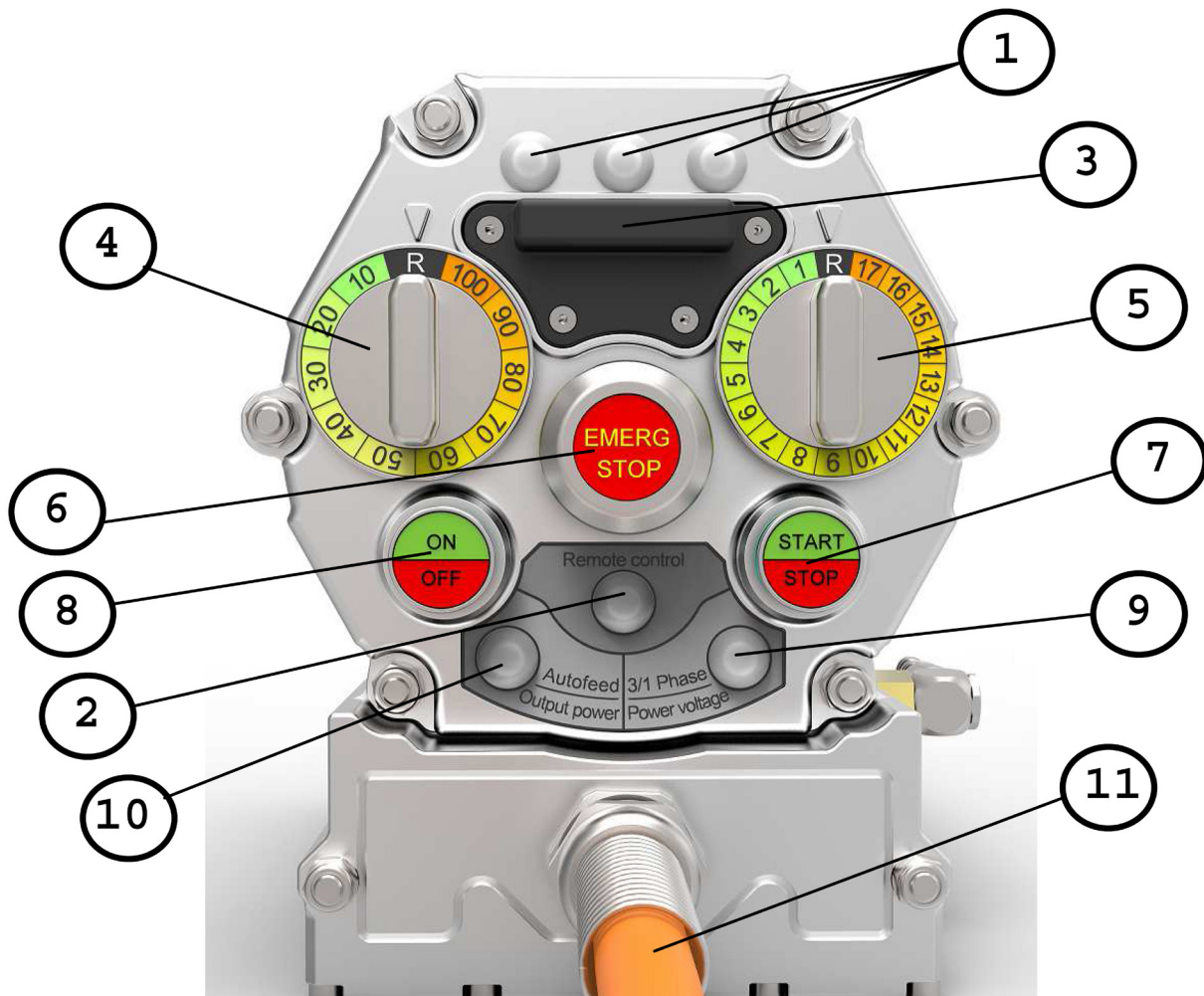

7.3 Drill motor operating modes

1 - When the drill motor power cable is energized, the motor automatically switches to Emergency Stop Mode. The status LED will be blinking with RED color.
 To switch to working mode, press and hold **START/STOP** button for 2 seconds. The input power voltage LED will start lighting as shown in the table:

Input power voltage LED state

Power Voltage	Input Power Voltage		Input Power Voltage LED Indication		
	1 phase	3 phases	Steady Color	Blink 1.0 sec with one color	Blink 1.0 sec with two colors
Single phase or Three phase $V \leq 190$	+	-	-	GREEN	-
	-	+	-	YELLOW	-
Single phase or Three phase $190 < V \leq 280$	+	-	GREEN	-	-
	-	+	YELLOW	-	-
Three phase $280 < V \leq 350$	-	One phase is missing	-	-	LIGHT BLUE /RED
	-	+	-	LIGHT BLUE	-
Three phase $350 < V \leq 440$	-	One phase is missing	-	-	BLUE /RED
	-	+	BLUE	-	-
Three phase $440 < V$	-	One phase is missing	-	-	VIOLET /RED
	-	+	VIOLET	-	-

NOTE: Drill electric motor (European version) operates in the following allowed voltage range: from 180V to 500 V max - AC 50Hz, 60Hz.

NOTE: When motor is powered from 3-phase source, a loss of a phase **will not damage the motor** or stop its operation (only output power will decrease).

2 - When input power voltage LED starts indicating the input voltage, the Drill's RPM can be set to desired position using the **Spindle Speed wheel**.

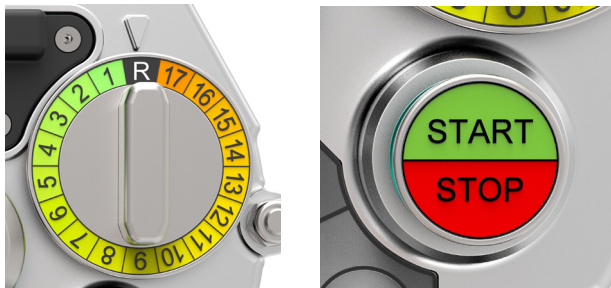

To start drill motor, after the drill motor RPM is set, press **START/STOP** button. When the motor is rotating, motor control system keeps RPM stable and the LEDs indicating the motor load light as follows:

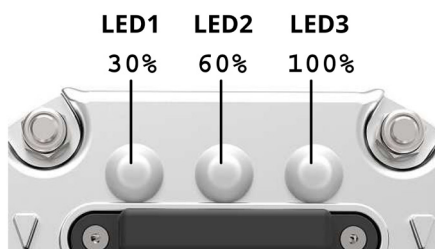

Output Power limit button is switched off.

Load	Status LED1	Status LED2	Status LED3
Load ≤ 30%	GREEN	-	-
30% < Load ≤ 60%	GREEN	GREEN	-
60% < Load ≤ 80%	GREEN	GREEN	GREEN
80% < Load ≤ 90%	GREEN	GREEN	YELLOW
90% ≤ Load	GREEN	GREEN	RED

Load is counted as percentage of the nominal output power **Pnom**.

Output Power limit button status

To work with a small drill bit or with a drill bit with weakened segments, operator can engage the motor power restriction mode by pressing Output Power Limit button.

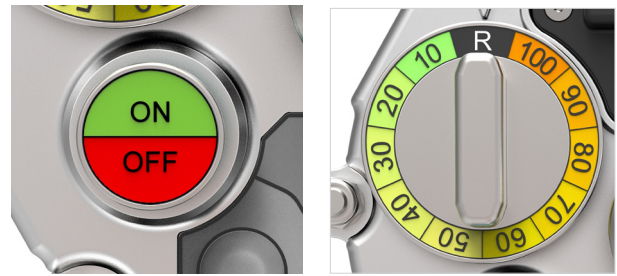

When output power limit button is activated, the output power can be set by Power Wheel in positions between 10% and 100%, in increments of 10. Power limit LED lights as follows:

Power Limit Button Status	Power Limit LED
ON	LIGHT BLUE
OFF	-
* Autofeed mode ON	GREEN

*Note: applies to CM-10AF motors only.

Output Power limit button is switched on.

When Output Power Limitation mode is switched on, the left knob sets the maximum level of output power Pout as percentage of nominal output Pnom.

Power limit wheel position	Load %	LED1	LED2	LED3
10-40 (10% ≤ Pout ≤ 40%)	Load ≤ 80%	GREEN	-	-
	80% < Load ≤ 90%	YELLOW	-	-
	90% < Load ≤ 100%	RED	-	-
40-70 (40% < Pout ≤ 70%)	Load ≤ 40%	GREEN	-	-
	40% < Load ≤ 80%	GREEN	GREEN	-
	80% < Load ≤ 90%	GREEN	YELLOW	-
70-100 (70% < Pout ≤ 100%)	90% < Load ≤ 100%	GREEN	RED	-
	Load ≤ 30%	GREEN	-	-
	30% < Load ≤ 60%	GREEN	GREEN	-
	60% < Load ≤ 80%	GREEN	GREEN	GREEN
	80% < Load ≤ 90%	GREEN	GREEN	YELLOW
90% < Load ≤ 100%	GREEN	GREEN	RED	

Note: "R" position in the Power Limit Wheel applies to the CM-10AF motor versions only.

When motor is running, the motor Spindle RPM can be set by changing position of **Spindle Speed Wheel** to any position between 1 and 17.

When position "R" is set, the motor will first automatically stop. Status LED LED1 will light with light blue color. If the **START/STOP** button is subsequently pressed, the motor will start rotating

in reverse direction and status LEDs LED1, LED2, LED3 will light with blue color. If the motor cannot start or accidentally stops, three status LEDs will alternately light in red and blue color and if the motor software detects a hardware problem, **motor will beep repeatedly with period of 1 sec.**

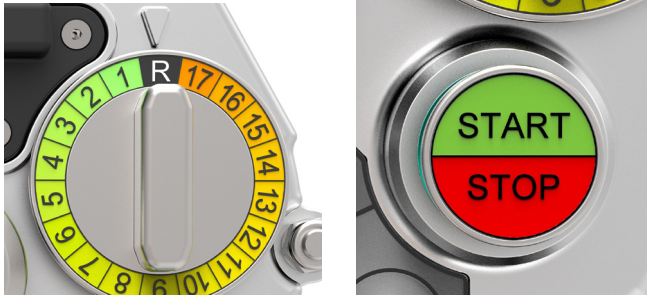

position, and the motor will start to slowly rotate in reverse direction.

5 - EMERGENCY STOP button is intended for averting or preventing personal injury or damage to the machine. When it is pressed the motor will stop and the LEDs LED1, LED2, LED3 will blink with the red light. The electronic system blocks the motor and control buttons operation.

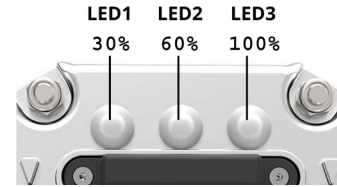

To return the motor to operation after the Emergency Stop Button has been activated, the **START/STOP** button needs to be pressed and held for 2 seconds, then the motor will be ready for starting again.

Errors indication.

ERROR DESCRIPTION	Status LED1	Status LED2	Status LED3	Beep	Blink
Low speed current loop overcurrent	RED	BLUE	BLUE	+	-
Overheating	RED	-	-	+	-
Inductance measurement overcurrent	RED	GREEN	GREEN	+	-
Drivers fault (overload)	RED	RED	-	+	-
Overvoltage	RED	GREEN	-	+	-
The motor jammed, startup error or timeout	RED	BLUE	-	+	-
EMRGENCY STOP	RED	RED	RED	+	+
Drivers locked	-	RED	-	+	-
CAN network TIMEOUT	RED	LIGHT BLUE	LIGHT BLUE	+	-
Drivers fault and locked	-	-	VIOLET	+	-
Reserved	-	-	RED	+	-
Reserved	RED	VIOLET	LIGHT BLUE	+	-
SERVICE ALERT	BLUE	BLUE	BLUE	-	+



- 3 - To stop drill motor, push **START/STOP** button.
- 4 - When position "R" is set, the motor will automatically stop.



To start the motor in reverse, the **START/STOP** button is to be pressed while wheel is in "R"

7.4 Motor Spindles RPM.

CM-10 spindles RPM table 3-phase 400V

Speed Wheel Position	SG15 gearbox (rpm)	SG30 gearbox (rpm)	SG60 gearbox (rpm)
1	80	40	20
2	120	60	30
3	200	100	50
4	280	140	70
5	400	200	100
6	520	260	130
7	640	320	160
8	780	390	195
9	900	450	225
10	1020	510	255
11	1160	580	290
12	1300	650	325
13	1440	720	360
14	1580	790	395
15	1720	860	430
16	1860	930	465
17	2000	1000	500

CM-10 spindles RPM table single-phase 230V

Speed Wheel Position	SG15 gearbox (rpm)	SG30 gearbox (rpm)	SG60 gearbox (rpm)
1	80	40	20
2	120	60	30
3	200	100	50
4	280	140	70
5	400	200	100
6	520	260	130
7	640	320	160
8	780	390	195
9	900	450	225
10	1020	510	255
11	1160	580	290
12	1300	650	325
13	1400	700	350
14	1440	720	360
15	1500	750	375
16	1560	780	390
17	1600	800	400

7.5 Start of core drilling

- Before switching on the power of the drill motor, move the motor so that the core bit is close to the material to be drilled. Set the spindle speed to minimum RPM (position 1).
- Open the water valve and water should start coming out from the centre of the core drill bit. Remember that too little water can cause the diamond segments to overheat but too much water flow washes away the abrasive slurry which is needed to prevent the segment from wearing away and to keep fresh diamonds exposed.
- While holding the feed handle securely, switch the locking mechanism of the carriage to "middle" position.
- When drilling vertically down (floor) or horizontally (wall) the lever should be in the "middle" position so that drill can be easily moved up or down (forward and backward).
When drilling vertically up (ceiling), position of the lever should be the "down" position to prevent drill motor from falling on the operator.



Note: The direction switch can get "stuck" when drill is mounted, and in this case, to get it to move freely again, it is necessary to move the drill slightly with the crank, just one click is enough, and then move the switch again, it should move freely to another position at that point.

- When the motor is switched on, make sure the core bit is not vibrating, and if excessive vibration of the core bit is detected – stop, and change the core drill bit.
- Move the core drill motor and the rotating core

bit closer to the material and, pressing lightly, drill about 1-2 cm into the material. This approach results in good centering and makes drilling much easier.

- After the drill bit is centered, increase the core drill motor forward speed and apply more contact pressure, until one of status indicator LEDs lights with yellow or red color (see chapter 7.3). The optimal spindle speed depends on the drill bit diameter, type of concrete and rebar amount. Remember that having forward speed too low leads to polishing of diamond sectors but having excessively high forward speed causes segments to wear sooner.
- In case of over-drilling, when a new larger diameter hole must be drilled around the existing hole of smaller diameter, the diameter of the new hole must be at least 15-20 mm larger than the diameter of the existing one.
- Small parts of the drilled material can jam the core bit. If you encounter this problem, stop the drill motor, pull the core out of the hole and remove all the parts that were jamming the core bit and then continue with drilling operations.
- In case the electric power unexpectedly goes off, the drill motor automatically switches to the Emergency stop mode. This mode protects operator from injury by blocking the operation of the motor and motor controls, in case the power unexpectedly turns back on. To restart drill motor, press and hold the **START/STOP** button for 2 seconds, release it and then press it again.

7.6 Drilling through iron

- When core bit starts cutting steel, the drill motor movement would slow and color of the slurry usually would change to brown or gray. Drop the motor speed down a little and decrease the pressure. Make sure that the water flow is quite high when drilling in iron, to prevent the core bit segments from getting overheated.

7.7 Angled drilling

- Set the spindle speed to minimum RPM (position1), move the core drill motor and the rotating core bit closer to the material and pressing lightly, while avoiding excessive core bit vibration, drill until the entire drill bit circumference penetrates the material.
- Increase the core drill motor forward speed and contact pressure, while avoiding excessive core bit vibration.

7.8 Drilling with a large-diameter or a longer drill bit

- Drilling holes larger than 0.4 meter in diameter, or holes deeper than 1.5 meter requires special care from the operator.
- Use two anchors, not less than M16 in size, as widely spaced in the drill base plate anchor slot as possible.
- To secure properly the base plate, fix the anchor bolts evenly, then use the leveling screws to tighten the drill base against the anchor bolt or stud.
- Make sure that the drill motor is properly fixed on the carriage and carriage rollers are snugly adjusted to the track with the eccentric bolts. This will eliminate excessive vibration during the drilling
- Set the spindle speed to minimum RPM (position1), move the core drill motor and the rotating core bit closer to the material and, pressing lightly, drill about 1-2 cm into the material. This approach results in a good alignment from the start and subsequently the friction between the drill bit and the walls of the hole will be greatly reduced and the motor power during the drilling will be much lower.
- After the drill bit is centered, increase the core drill motor forward speed and contact pressure. The optimal spindle speed depends on the drill bit diameter, type of concrete and rebar amount.

7.9 Core bit jamming

- In case of a core bit jamming be ready to turn off the drill motor.
- CM-10 drill motor is equipped with a slip mechanical clutch that disengages the core bit from the motor when the torque on the core bit exceeds the maximal allowed value. In this way the clutch safeguards gear wheels, shafts and other drive elements of the drill motor from damage and thus guarantees operational reliability.
- In case of jamming, switch the motor off immediately.



WARNING: Do not attempt to unclamp the core bit when the motor is switched on!

- Try to unclamp the core bit by rotating the bit in reverse with your core drill wrench, taking care not to damage the core bit. Usually this action will release the wedge enough for you to pull the bit from the hole.

7.10 Deep drilling with shaft extension

The shaft extension rods allow drilling deeper than the length of the core drill bit:

- Follow the above operating instructions, drill up

to the end of the core bit.

- Stop the drill motor, pull the core bit out of the hole and remove the core.
- Place and secure the proper core bit extension rod between the core bit and the core drill motor.
- Insert the core bit into the hole and proceed drilling.

7.11 Reverse gear

The reverse gear can be used for removing the diamond drill bits.

When RPM wheel is set to "R" while the motor is running, the spindle will automatically stop. The motor status LEDs will change color to light blue.

When the spindle has stopped, push the motor **START/STOP** button and the spindle will start slowly rotating in reverse direction.

8. Service time alert

Indicates that service is required. After the machine total cumulative run time reaches 200 hours, when the power is connected, LED1, LED2, LED3 LED's will blink with 1Hz frequency with blue colour light for 30 seconds. After 250 hours run time is reached, the warning signal for service is stopped automatically and will no longer flash.



WARNING: If the machine has NOT been serviced by an authorised service workshop after 250 hours of run time, the "service required" signal is not reset, and remains in the memory as a fault code. **This will void the manufacturer warranty!**

9. Maintenance

- Unplug the core drill motor before starting cleaning or maintenance operation.
- Never use solvents or other harsh chemicals for cleaning your core drill motor.
- Never use spray systems, high-pressure water jet systems or steam pressure cleaning systems for motor cleaning. The drill motor should be cleaned with a brush and water.
- Keep the core drill motor clean and dry, in particular its cable and connectors.
- To remove water from the motor cooling jacket, put the drill motor in vertical position, open the water valve, swivel the motor hose upwards and wait until the motor is drained.
- The core-bit shaft thread should be kept lubricated. We recommend anti-seize copper or

graphite lubricants.

- Never unplug the core drill motor by pulling by the cord, pull only by the plug.
- Prior to operating the drill motor, inspect the feeding cable and extension cords, making sure they don't have any damage. If you find a damage, ask authorized service centre for replacements.

10. Transportation

During transportation, loading, and unloading of the motor its integrity must be ensured.

The motor should be packaged in the original (preferably) or comparable box.

Motors are allowed to be transported by any kind of covered transport at any distance.

When transporting the motor, the motor should be positioned horizontally and its shaft axis must be positioned perpendicular to the direction of movement of the vehicle to prevent damage to the bearings.

When transporting and moving motors, it is necessary to ensure they don't come into contact with other items in such a way that can cause damage.

11. Storage and preservation

The following conditions must be met when storing drill motors:

- motors should be stored within or without packaging in a dry and ventilated warehouse free from vibration and dust;
- the atmosphere of the warehouse should not contain acid, alkaline and other vapors, harmful to insulation and coatings;
- during storage there should be no fluctuations in temperature and humidity, which cause the dew formation;
- when storing boxed motors, inscriptions and markings on the packaging should be followed.

12. Troubleshooting

Problem	Probable cause	Solution
The motor does not start and motor LED lights are not lighting.	<ul style="list-style-type: none"> No power supply. Motor connection problem. The power cord is damaged. 	<ul style="list-style-type: none"> Check the power supply. Check the motor connection. Replace the power cord.
The motor does not start and the motor status lights are blinking with red color.	The motor is in Emergency Stop Mode.	Press and hold the START/STOP button for 2 seconds, release. To start the drill motor, press the button again.
The motor doesn't start and the motor LED lights show Error code.	Failure in the electronic system of the motor.	Press the START/STOP button and release. To start the drill motor, press the button again. If the motor doesn't start, unplug the motor from the power and wait 2 seconds. Connect the power again and try to start the motor again. If the motor doesn't start and shows Error again, it will need to be repaired by KASKOD-MTR ONIX Service.
Connected to 3-phase power, the motor doesn't have enough output power and power LED indicator blinks with red color.	One phase is missing The power cord is damaged.	Check the motor power feed connection. Missing a phase will not damage the motor. Replace the power cord.
The motor doesn't start and the motor LED lights show overheating.	The motor has overheated.	<ul style="list-style-type: none"> Switch off the motor. Check the water supply. Wait until the motor is cooled down and then it will be ready for use again.
The motor starts and then turns off. The motor status lights show overload.	The core bit is stuck in the concrete.	Remove the core bit.
Noisy operation.	<ul style="list-style-type: none"> Bolts of spindle gearbox are loose. Dry spindle or motor gearbox. Broken bearing. 	<ul style="list-style-type: none"> Tighten the spindle gearbox. Have spindle gearbox lubricated by KASKOD-MTRONIX Service. Have broken bearing replaced by KASKOD-MTRONIX Service.
Excessive wobbling of the spindle and diamond core bit.	<ul style="list-style-type: none"> Bolts of spindle gearbox are loose. Worn spindle shaft or bearings. Diamond core bit is not tightened. Diamond core bit is bent or damaged. 	<ul style="list-style-type: none"> Tighten the spindle gearbox Replace worn shaft and bearing. Tighten the core bit. Replace the core bit.
Excessive wobbling of the drill rig and motor with core bit.	The leveling screws or anchor are not tightened.	Tighten the screws and anchor.
Excessive wobbling of the motor or motor with carriage.	<ul style="list-style-type: none"> The motor is not fixed properly. The eccentric bolts of the motor carriage are not tightened. 	<ul style="list-style-type: none"> Tighten the motor Tighten the eccentric bolts of the motor carriage.
Water leaking at the motor or gear housing.	<ul style="list-style-type: none"> The water pressure is too high. The motor or gearbox shaft seals or O-rings are defective. 	<ul style="list-style-type: none"> Reduce the water pressure The motor will need to be repaired by KASKOD-MTRONIX Service.
Drilling feed speed decreases.	<ul style="list-style-type: none"> The drill bit is completely sunk in concrete and cannot move deeper. The diamond core bit is damaged or diamond core segments are worn. The water flow is too low or too high. Sleep clutch of the motor is worn. 	<ul style="list-style-type: none"> Remove the core and use a shaft extension rod to continue drilling. Replace the core bit. Adjust the water flow. The motor will need to be repaired by KASKOD-MTRONIX Service.

13. Manufacturer's warranty

Please contact KASKOD-MTRONIX to get information about warranty conditions.

14. End-of-life product disposal



This product cannot be disposed of as household waste. At the end of its life, the product must be transferred to an appropriate collection point for processing electrical and electronic equipment.

Ensure that this product is disposed of correctly. It will help to prevent potential negative consequences for the environment and human health.

Alternatively, you may contact the distributor you purchased the product for disposal information.

15. Declaration of conformity

The manufacturer:

Name: KASKOD-MTRONIX OÜ
Address: Posti 27, Loksa, 74805, Estonia
Email, web: info@kaskod.ee, www.kaskod.com

Declares that the below described machine:

Description: CUTTRONIX CM-10 Core Drill and CUTTRONIX DRU Drill Rig
Type: CUTTRONIX CM-10 and DRU
Designed in: 2019

Is in conformity with the following provisions and norms:

Machinery Directive 2006/42/EC.
Low Voltage Directive (2014/35/EU)
EMC-Directive 2014/30/EU
DIN EN ISO 12100:2010 Safety of machinery – Basic concepts, general principles for design
DIN EN 12348 +A1; 2009 Core drilling machines on stand – Safety.
EVS-EN 60204-1:2018,
EVS-EN 60529:2001+A2:2014
EVS-EN 55011:2015,
EVS-EN 55014-2:2015

Changes in product design or characteristics and changes in the harmonized standards or in technical specifications by reference to which conformity of a product is declared will be taken into account by the manufacturer to ensure that the currently manufactured products are in conformity with the safety provisions and norms.

29.05.2019
Loksa, Estonia



Managing Director Andrei Krianev, Ph.D